



Mission Rubber Company LLC

1660 Leeson Lane
 Corona, CA 92879
 (800) 854-9991 • Fax (800) 637-4601
 missionrubber.com

MISSION
 RUBBER COMPANY

*Unshielded flexible
 sewer couplings that
 connect similar and
 dissimilar pipe materials
 and sizes*

MEETS:
 ASTM C 425
 ASTM C 1173
 ASTM A240/A240M
 CSA B602
 UPC 4224



Flex-Seal® Sewer Coupling - Submittal MR55 Series

*Performance Couplings for Similar and Dissimilar Pipe Sizes
 and Materials*

PROJECT _____

ENGINEER _____

CONTRACTOR _____

Worm Drive Clamp Gasket 300 series ASTM stainless steel
 This gasket is fabricated from a compound with high-quality elastomeric properties to meet physical testing.

MATERIALS

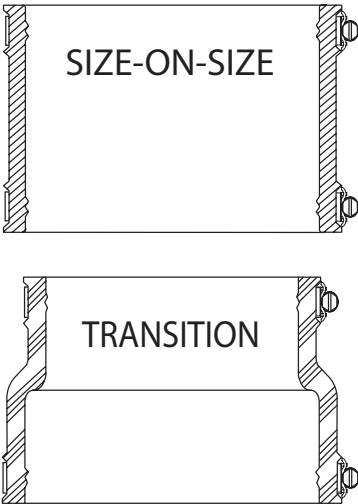

WORM DRIVE CLAMP DETAILS

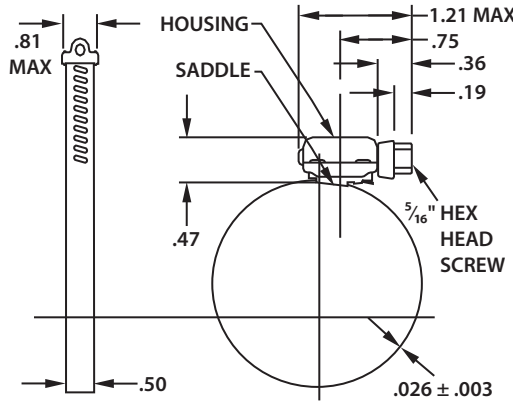

SEALING GASKET DETAILS

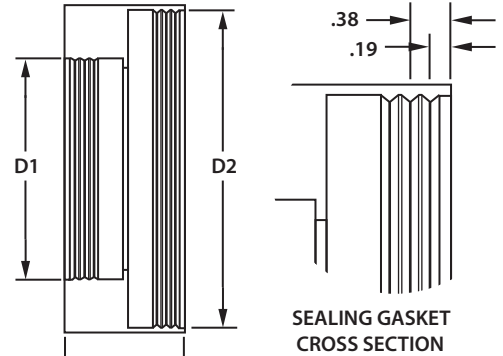

MISSION REFERENCE MR55 SERIES	SEALING GASKET DIMENSIONS		
	D1	D2	W
MR55 44	4.93	4.93	4.00
MR55 54	4.93	5.93	6.00
MR55 55	5.93	5.93	6.00
MR55 64	4.93	7.12	6.00
MR55 65	5.93	7.12	6.00
MR55 66	7.12	7.12	6.00
MR55 86	7.25	9.25	6.00
MR55 88	9.25	9.25	6.00
MR55 1008	9.25	11.20	6.00
MR55 1010	11.20	11.20	6.00
MR55 1212	13.50	13.50	6.00
MR55 1616	17.90	17.90	10.00
MR55 1818	19.60	19.60	10.00

TEST	GASKET PHYSICAL TESTS (ASTM C 425)	ASTM C 425
Tensile Strength	1000 PSI minimum	D412
Elongation	250% minimum	D412
Durometer (Shore A)	55 minimum 70 maximum	D2240
Accelerated Aging	85% of original tensile strength 85% of original elongation All determined after oven aging at 70°C for 7 days	D573
Compression Set	20% maximum of original deflection	D395
Ozone Cracking	No visible cracking at 2X magnification of the gasket after 24 hours exposure in 0.5 PPHM ozone concentrations at 40°C. Testing and inspection to be on gasket which is loop-mounted to give approximately 20% elongation of outer surface.	D1149
Water Absorption	5% maximum by weight after 7 days at 70°F	D471

Used to Join - MR55 Series couplings are used to join asbestos cement or ductile iron to asbestos cement or ductile iron.

Mission's Flex-Seal® Unshielded Coupling is a flexible sewer coupling designed to connect similar and dissimilar pipe materials and sizes. Coupling consists of two (2) 300 series stainless steel worm drive clamps over a molded one-piece elastomeric sealing gasket. MR55 Series couplings are available in sizes 4" to 18".

Leak-Proof Seal - Stainless steel clamps provide a positive seal when properly tightened to 60 in/lbs. of torque. Axially slotted clamps enable bands to tighten independently to accommodate variances in the outside diameters of the pipe to be joined, ensuring a water-tight, leak-proof and root-proof seal. Sealing "O" Rings are installed under each sealing clamp to prevent pipe slippage and create a more positive seal.

Corrosion Resistant - Use of 300 series stainless steel components are highly effective in a variety of environments; such as marine applications, poorly aerated or moist soils, contaminated ground conditions (particularly industrial fill sites) and where the ground water contains chloride, sulfates or bicarbonates.

Withstands Tension and Compression - Synthetic rubbers permit a substantial degree of distortion without change in basic physical resistance, unlike other manufacturers' thermoplastic coupling materials. Molded synthetic rubber gasket is strong, durable and resilient to ultraviolet rays, ozone, fungus growth, natural erosive properties and normal sewer gases. More pliable and easier to install in cold weather applications than an elastomeric PVC gasket.

Pre-Set Calibration - All Flex-Seal® Unshielded Couplings are designed to be installed with a pre-set torque wrench calibrated to 60 in/lbs. maximum to accommodate the 300 series stainless steel 5/16" hex head screw.