



Mission Rubber Company LLC

1660 Leeson Lane
 Corona, CA 92879
 (800) 854-9991 • Fax (800) 637-4601
 missionrubber.com

MISSION
 RUBBER COMPANY

**For Installations
 Requiring a Shielded
 Transition Coupling that
 Joins Similar and
 Dissimilar Pipe Sizes
 and Pipe Materials**

MEETS:
 ASTM C 1460
 ASTM C 564
 ASTM A240/A240M
 CSA B602
 UPC 0743

Band-Seal® Coupling - Submittal C Series

*Performance Couplings for Similar and Dissimilar Pipe Sizes
 and Materials*

PROJECT _____

ENGINEER _____

CONTRACTOR _____

MATERIALS	
Band	Series 301 ASTM stainless steel
Screw Housing	Series 301 ASTM stainless steel
Screw Saddle	Series 301 ASTM stainless steel
Screw	Series 305 ASTM stainless steel
Shield	Series 301 ASTM stainless steel
Gasket	This gasket is fabricated from a compound with high-quality elastomeric properties to meet physical testing.

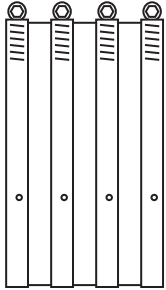

SIZES ¾" THROUGH 4" - 2 BANDS
 SIZES 5" THROUGH 12" - 4 BANDS

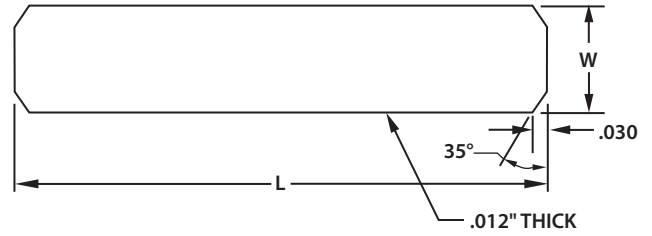
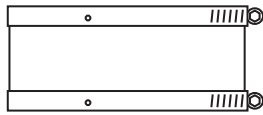

SHIELD DETAILS

CLAMP DETAILS

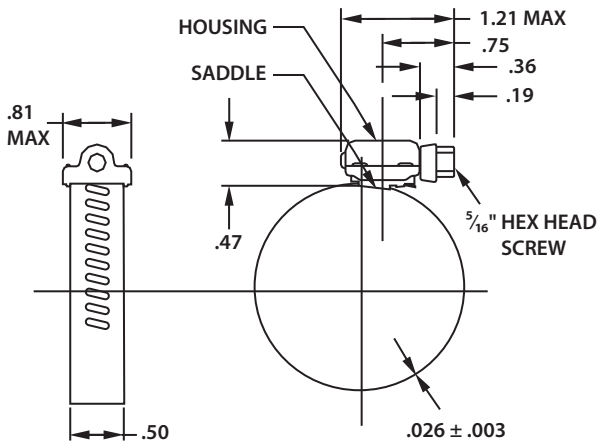

SEALING GASKET CROSS SECTION DETAILS

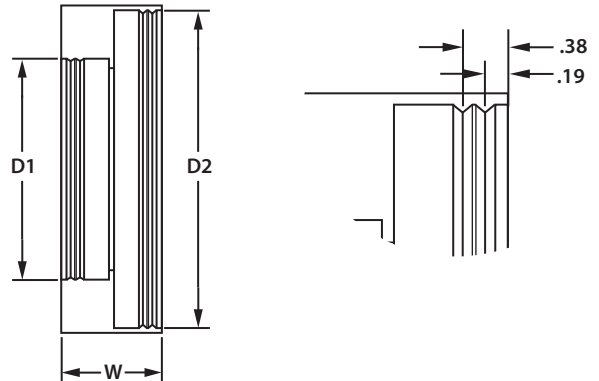

MISSION REFERENCE C SERIES	SHIELD DIMENSIONS		SEALING GASKET DIMENSIONS		
	L	W	D1	D2	W
C 315	12.69	2.12	1.90	3.35	2.12
C 320	12.69	2.12	2.35	3.35	2.12
C 420	16.00	2.12	2.35	4.38	2.12
C 430	16.00	2.12	3.35	4.38	2.12
C 530	18.50	3.00	3.35	5.30	3.00
C 540	18.50	3.00	4.38	5.30	3.00
C 640	21.75	3.00	4.38	6.30	3.00
C 650	21.75	3.00	5.30	6.30	3.00

TEST	GASKET PHYSICAL TESTS (ASTM C 564)	ASTM C 564
Tensile Strength	1500 PSI minimum	D412
Elongation	250% minimum	D412
Durometer (Shore A)	70 ± 5 @ 76°F ± 5°F	D2240
Accelerated Aging	15% maximum tensile and 20% maximum elongation deterioration. 10 points maximum increase in hardness. All determinations after oven aging for 96 hours at 158°F.	D573
Compression Set	15% maximum after 22 hours at 158°F	D395
Oil Immersion	80% maximum volume change after immersion in ASTM oil #3 for 70 hours at 212°F	D471
Ozone Cracking	No visible cracking at 2X magnification of the gasket after 100 hours exposure in 1.5 PPHM ozone concentration at 100°F. Testing and inspection to be on gasket which is loop-mounted to give approximately 20% elongation of outer surface.	
Tear Resistance	Die C 150 lbs. minimum per inch of thickness	D624
Water Absorption	20% maximum by weight after 7 days at 158°F	D471

Used to Join - C Series couplings are used to join cast iron to cast iron, plastic or steel for C 315, C 320 & C 420; and cast iron to cast iron in remaining products.

Mission's Band-Seal® Specialty Coupling is a shielded transition coupling designed to connect similar and dissimilar pipe sizes and materials. Coupling consists of two (2) or four (4) 301 series stainless steel worm drive clamps, a 300 series stainless steel shield, over a molded one-piece elastomeric sealing gasket. C Series couplings are available in sizes 1½" to 6": 3" to 4" sizes utilize two (2) clamps; 5" to 6" sizes utilize four (4) clamps.

Leak-Proof Seal - Stainless steel clamps provide a positive seal when properly tightened to 60 in/lbs. of torque. Sealing "O" Rings are installed under each sealing clamp to prevent pipe slippage and create a more positive seal, ensuring a water-tight, leak-proof and root-proof seal.

Corrosion Resistant - 300 series stainless steel components provide highly effective corrosion resistance in a variety of environments.

Joint Movement Restraint - The Band-Seal® Specialty Coupling provides for superior load bearing control between the coupling and pipe surface. The coupling's rugged construction provides excellent sealing properties, and the stainless steel shield offers excellent resistance to shear forces and helps with alignment, while maintaining flexibility.

Internal Pipe Stop - For proper pipe positioning and noise/vibration reduction.

Pre-Set Calibration - All Band-Seal® Specialty Couplings are designed to be installed with a pre-set torque wrench calibrated to 60 in/lbs. maximum to accommodate the 305 series stainless steel 5/16" hex head screw.